



### Dishwashing

EVO Generation - Concept

## DISHWASHER CO-110 - 60 Hz

#### DIMENSIONS

		Article	Packed
Length	mm	658,00	700,00
Depth	mm	756,00	840,00
Height	mm	1.554,00	2.040,00
Weigth	Kg	145,00	166,00
Volumen	m3	0,77	1,20

#### ELECTRICITY

Electric power	KW	
230V -1+N		2x16+T - 63 A
230V - III		3x6+T - 40 A
400V - III+N		4x2,5+T - 25 A

#### WATER

Water consumption (lit/h)	108,00
Pressure (Kg/cm2)	2 ÷ 4

#### GAS

Not used

#### STEAM

Not used

#### AIR

Not used

#### LEVEL SOUND

(dB) 63,00

#### DISHWASHER CO-110 - 60 Hz

Hood type dishwasher - EVO Generation - Concept range.  
Hourly production: 40 baskets/hour - 720 dishes/hour.  
Clearance (max ware height): 440 mm.  
Wash cycles: 90"- 180".

Made of stainless steel.  
Counterbalanced hood.  
Double rotating wash and rinse systems, made of AISI-304 stainless steel.  
Wash pump, 600 W each.  
Tank with 4.5 kW heating power.  
Tank capacity: 34 litres.  
Boiler heating power: 6 kW.  
Boiler capacity: 9 litres.  
Water consumption: 2.4 litres/rinse.  
Thermostatic temperature control: washing at 60°C and rinsing at 90°C.  
Safety thermostats.  
Built-in automatic rinse dispenser and detergent doser.  
Built-in non-return valve.  
Safety magnetic switch for hood opening.  
Adjustable legs.  
Water protection rating: IPX4  
Total power: 6,60 / 11,1 kW. - 60 Hz  
Dimensions: 658 x 756 x 1540 mm.

Baskets equipment: 1 x CT-10, 1 x CP-16/18 and 2 cutlery containers.

Connections points	X	Y	Z	Diameter	Information
ELECTRICITY	210	50	65		
SOFT COLD WATER	305	50	65	3/4"	
DRAIN	370	50	65	30 x 25	

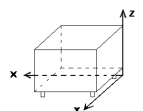

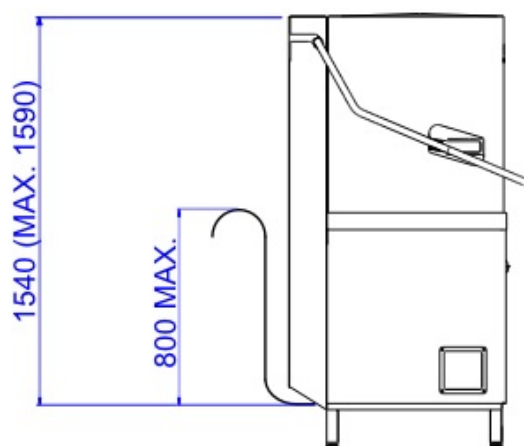
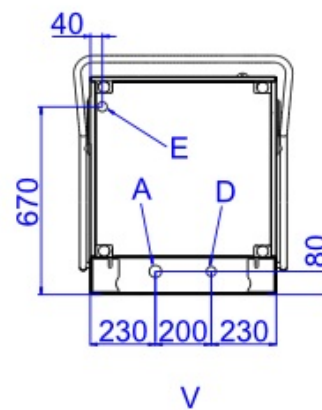
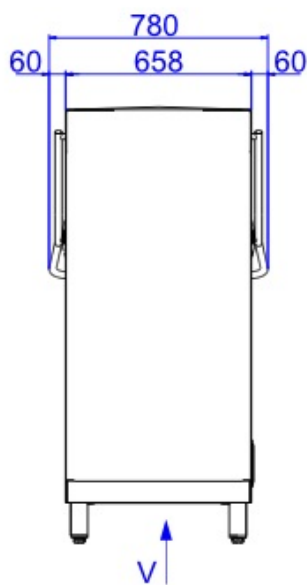
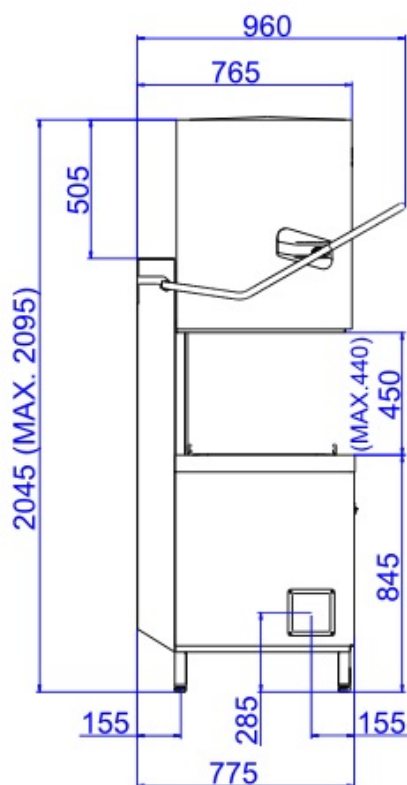

A: ENTRADA DE AGUA  
E: ALIMENTACIÓN ELÉCTRICA  
D: DESAGÜE

A: WATER INLET  
E: ELECTRICAL CONNECTION  
D: DRAIN

A: ARRIVÉE D'EAU  
E: CONNEXION ÉLECTRIQUE  
D: VIDANGE